

FRUITLAND PUMPS

OIL LEVEL SENSOR SYSTEM

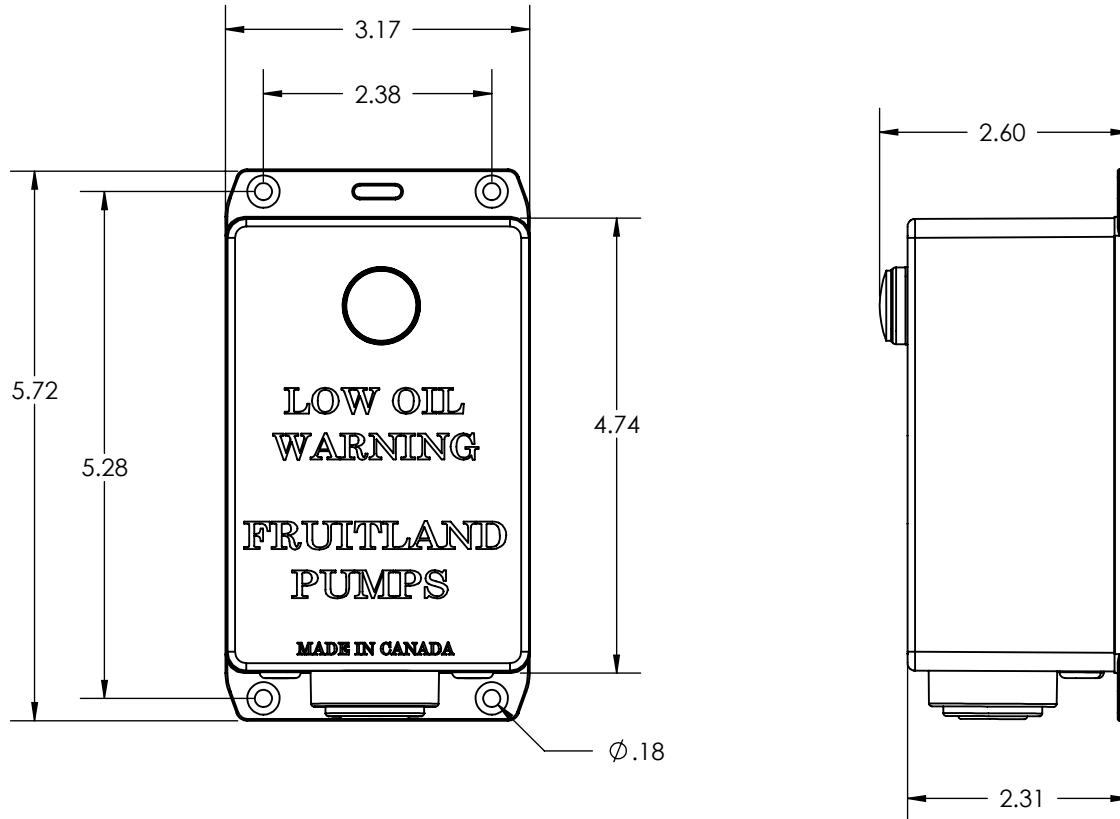

SPECIFICATIONS:

- **Power Supply** ----- = 12 VDC
- **Buzzer** ----- = 105 db.
- **Sensor Mounting Threads** ---- = 3/8" NPT Male
- **Cable Length** ----- = 10 ft.
- **Power Cable Length** ----- = 10 ft.

Data and capacities not binding
Company reserves the right to make changes